

### Surface Mount Superfast Recovery Rectifier

Reverse Voltage 850 to 600 V

Forward Current 83 A

### FEATURES

- "For surface mounted applications
- "Low profile package
- "Glass Passivated Chip Junction
- "Superfast reverse recovery time
- "Lead free in comply with EU RoHS 2011/65/EU directives

### MECHANICAL DATA

- "Case: SMAF
- " Terminals: Solderable per MIL-STD-750, Method 2026
- "A pprox. Weight: 27mg 0.00086oz

### PINNING

PIN	DESCRIPTION
1	Cathode
2	Anode

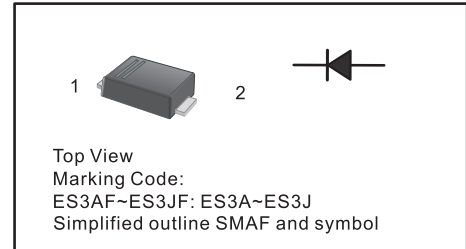

### Absolute Maximum Ratings and Characteristics

Ratings at 25 °C ambient temperature unless otherwise specified. Single phase, half wave, 60 Hz, resistive or inductive load. For capacitive load, derate current by 20%.

Parameter	Symbols	ES3AF	ES3BF	ES3CF	ES3DF	ES3EF	ES3GF	ES3JF	Units
Maximum Repetitive Peak Reverse Voltage	$V_{RRM}$	50	100	150	200	300	400	600	V
Maximum RMS voltage	$V_{RMS}$	35	70	105	140	210	280	420	V
Maximum DC Blocking Voltage	$V_{DC}$	50	100	150	200	300	400	600	V
Maximum Average Forward Rectified Current at $T_L = 100\text{ }^\circ\text{C}$	$I_{F(AV)}$	3							A
Peak Forward Surge Current 8.3 ms Single Half Sine Wave Superimposed on Rated Load (JEDEC Method)	$I_{FSM}$	100							A
Maximum Forward Voltage at 3A	$V_F$	1				1.25		1.7	V
Maximum DC Reverse Current at Rated DC Blocking Voltage $T_a = 25\text{ }^\circ\text{C}$ $T_a = 125\text{ }^\circ\text{C}$	$I_R$	5 200							%A
Typical Junction Capacitance at $V_R=4\text{V}$ , $f=1\text{MHz}$	$C_j$	45							pF
Maximum Reverse Recovery Time at $I_F=0.5\text{A}$ , $I_R=1\text{A}$ , $I_{rr}=0.25\text{A}$	$t_{rr}$	35							ns
Operating and Storage Temperature Range	$T_j, T_{stg}$	-55 ~ +150							$^\circ\text{C}$

**Fig.1 Reverse Recovery Time Characteristic And Test Circuit Diagram**

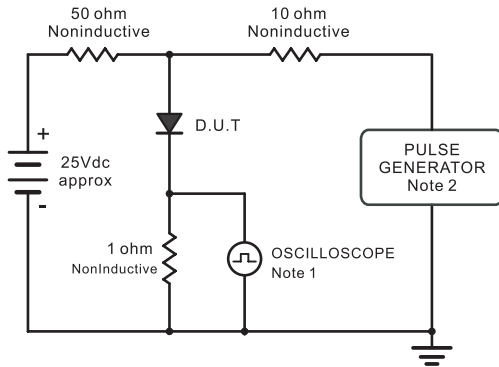

Note 1. Rise Time = 7ns, max.  
Input Impedance = 1megohm, 22pF.  
2. Rise Time = 10ns, max.  
Source Impedance = 50 ohms.

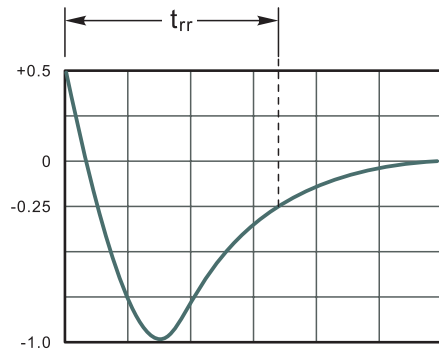

10ns/div  
Set time Base for 10ns/div

**Fig.2 Maximum Average Forward Current Rating**

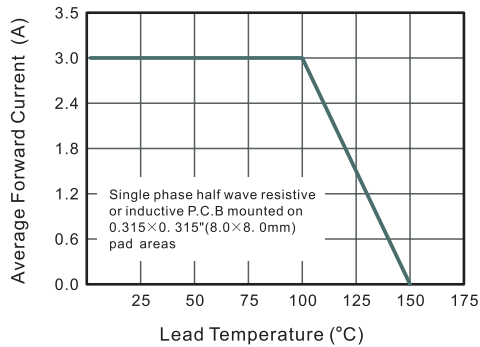

**Fig.3 Typical Reverse Characteristics**

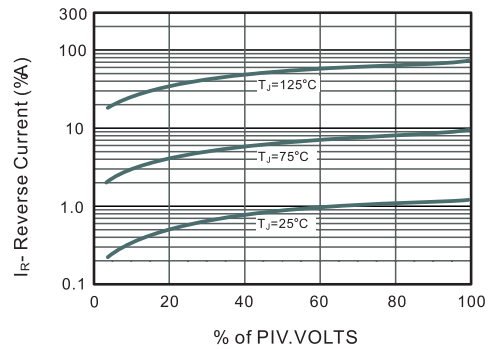

**Fig.4 Typical Forward Characteristics**

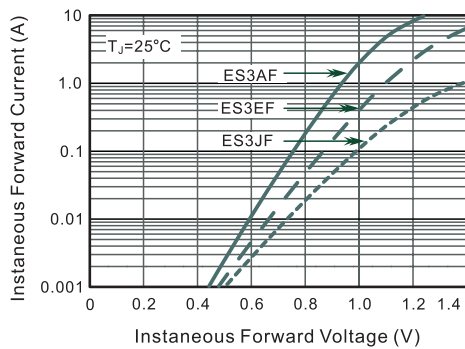

**Fig.5 Typical Junction Capacitance**

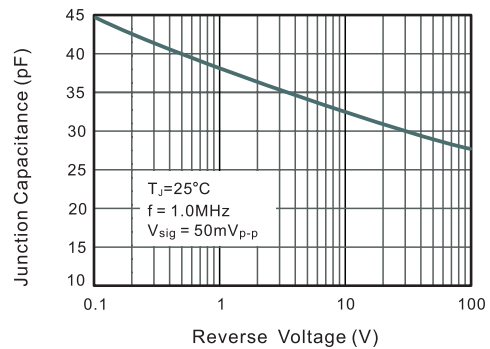

### PACKAGE OUTLINE

Plastic surface mounted package; 2 leads

SMAF

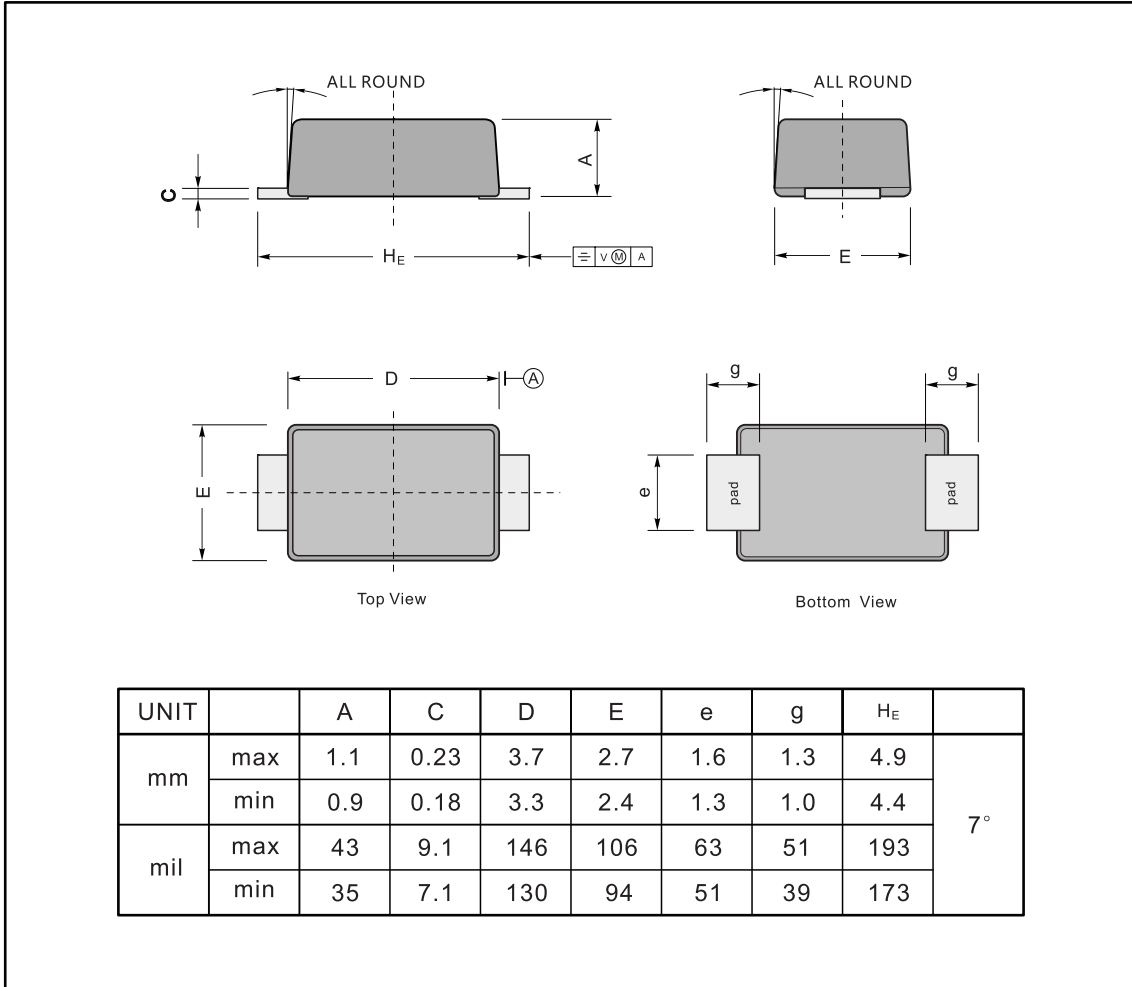

### The recommended mounting pad size

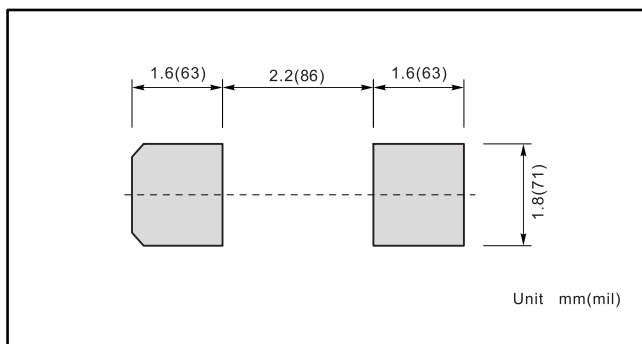

### Marking

Type number	Marking code
ES3AF	ES3A
ES3BF	ES3B
ES3CF	ES3C
ES3DF	ES3D
ES3EF	ES3E
ES3GF	ES3G
ES3JF	ES3J