

TRANSISTOR (NPN)

Equivalent Circuit:

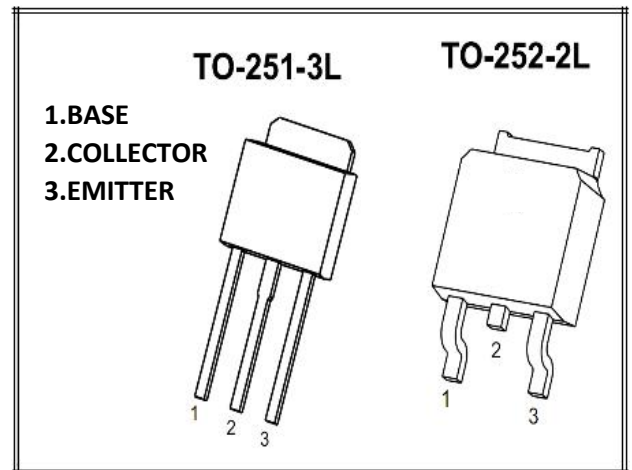
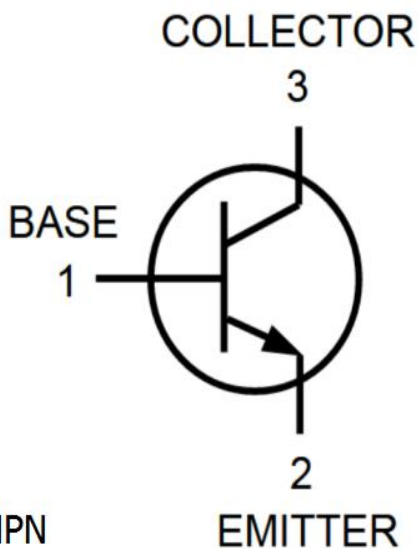

FEATURES:

- Complementary Darlington Power Transistors
- Dpak for Surface Mount Applications

MARKING:

MJD122 TSD ****

TSD→logo(D→252) / (U→251) ****→Date

MAXIMUM RATINGS (Ta=25°C unless otherwise noted)

Parameter	Symbol	Value	Unit
Collector-Base Voltage	VCBO	100	V
Collector-Emitter Voltage	VCEO	100	V
Emitter-Base Voltage	VEBO	5	V
Collector Current -Continuous	IC	4	A
Collector Current -Pulsed	ICM	2	A
Collector Power Dissipation	PC	1	W
Thermal Resistance From Junction To Ambient	RθJA	71.4	°C/W
Junction Temperature	Tj	150	°C
Storage Temperature	Tstg	-55~+150	°C



MJD112

TO-252/TO-251 Plastic-Encapsulate Transistors

ELECTRICAL CHARACTERISTICS (Ta=25°C unless otherwise specified)

Parameter	Symbol	Test Condition	Min	Typ	Max	Unit
Collector-base breakdown voltage	V(BR)CBO	IC= 1mA, IE=0	100			V
Collector-emitter breakdown voltage	V(BR)CEO	IC= 30mA, IB=0	100			V
Emitter-base breakdown voltage	V(BR)EBO	IE= 5mA, IC=0	5			V
Collector cut-off current	ICBO	VCB= 100 V , IE=0			20	μA
Collector cut-off current	ICEO	VCB= 50V , IE=0			20	μA
Emitter cut-off current	IEBO	VEB= 5V , IC=0			2	mA
DC current gain	hFE	VCE= 3V, IC= 500mA	500			
		VCE= 3V, IC= 2A	1000		12000	
	hFE	VCE= 3V, IC= 4A	100			
Collector-emitter saturation voltage	VCE(sat)	IC= 2A, IB= 8mA			2	V
	VCE(sat)	IC= 2A, IB= 40mA			3	V
Base-emitter saturation voltage	VBE(sat)	VCE= 3V, IB= 2A			2.8	V
Transition frequency	fT	VCE= 10V, IC= 0.75A f=1MHz	25			MHz
Collector output capacitance	Cob	VCB=20V, IE=0, f=1MHz			100	PF

TYPICAL ELECTRICAL AND THERMAL CHARACTERISTICS

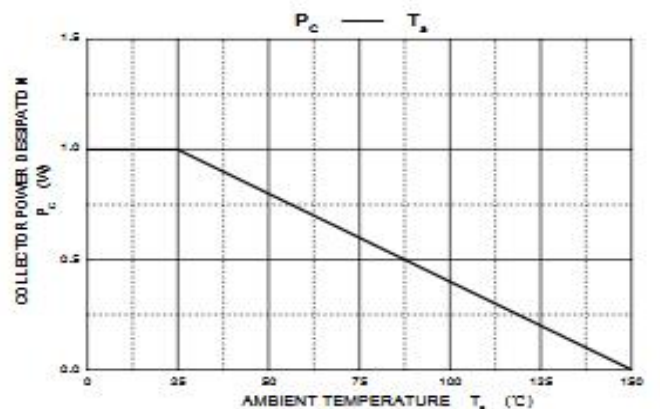
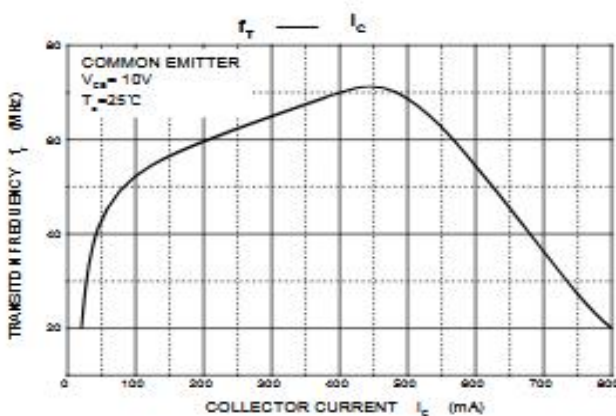
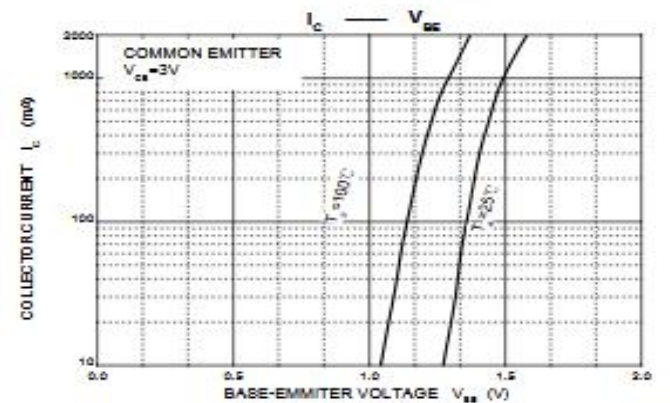
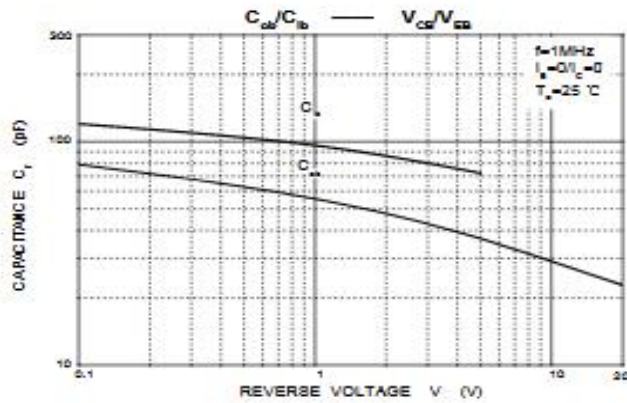
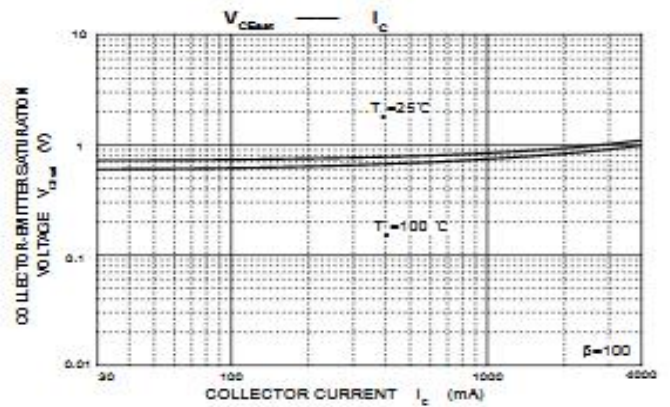
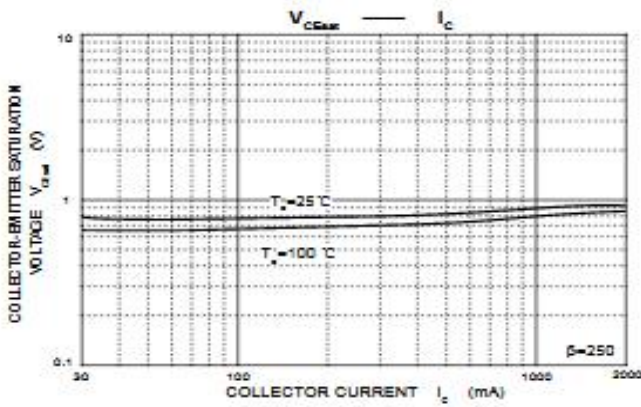
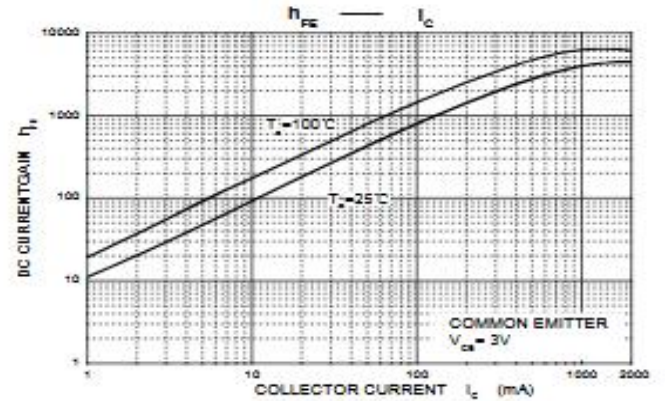
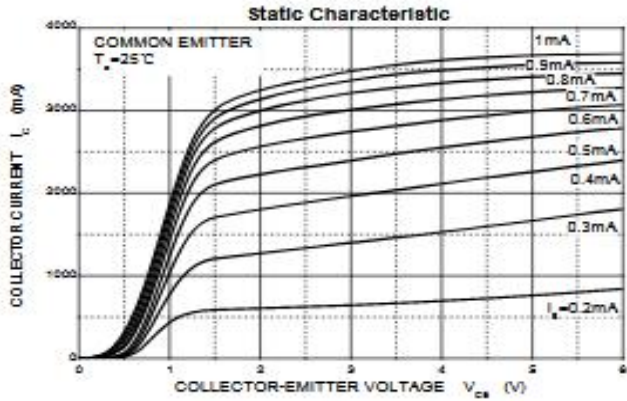

TO-252 PACKAGA OUTLINE DIMENSIONS

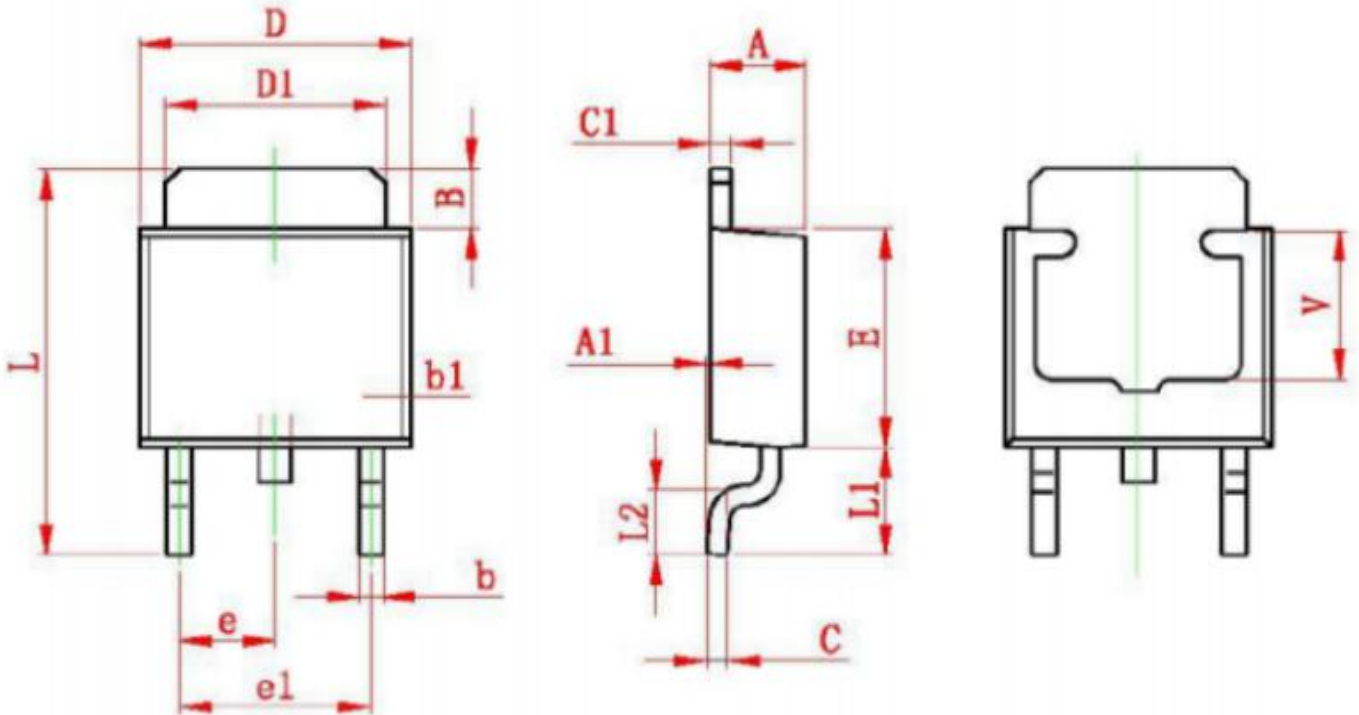

Symbol	Dimensions In Millimeters		Dimensions In Inches	
	Min	Max	Min	Max
A	2.200	2.400	0.087	0.094
A1	0.000	0.127	0.000	0.005
B	1.350	1.650	0.053	0.065
b	0.500	0.700	0.020	0.028
b1	0.700	0.900	0.028	0.035
c	0.430	0.580	0.017	0.023
c1	0.430	0.580	0.017	0.023
D	6.350	6.650	0.250	0.262
D1	5.200	5.400	0.205	0.213
E	5.400	5.700	0.213	0.224
e	2.300 TYP		0.091 TYP	
e1	4.500	4.700	0.177	0.185
L	9.500	9.900	0.374	0.390
L1	2.550	2.900	0.100	0.114
L2	1.400	1.780	0.055	0.070
V	3.80 REF		0.150 REF	

TO-251 PACKAGA OUTLINE DIMENSIONS

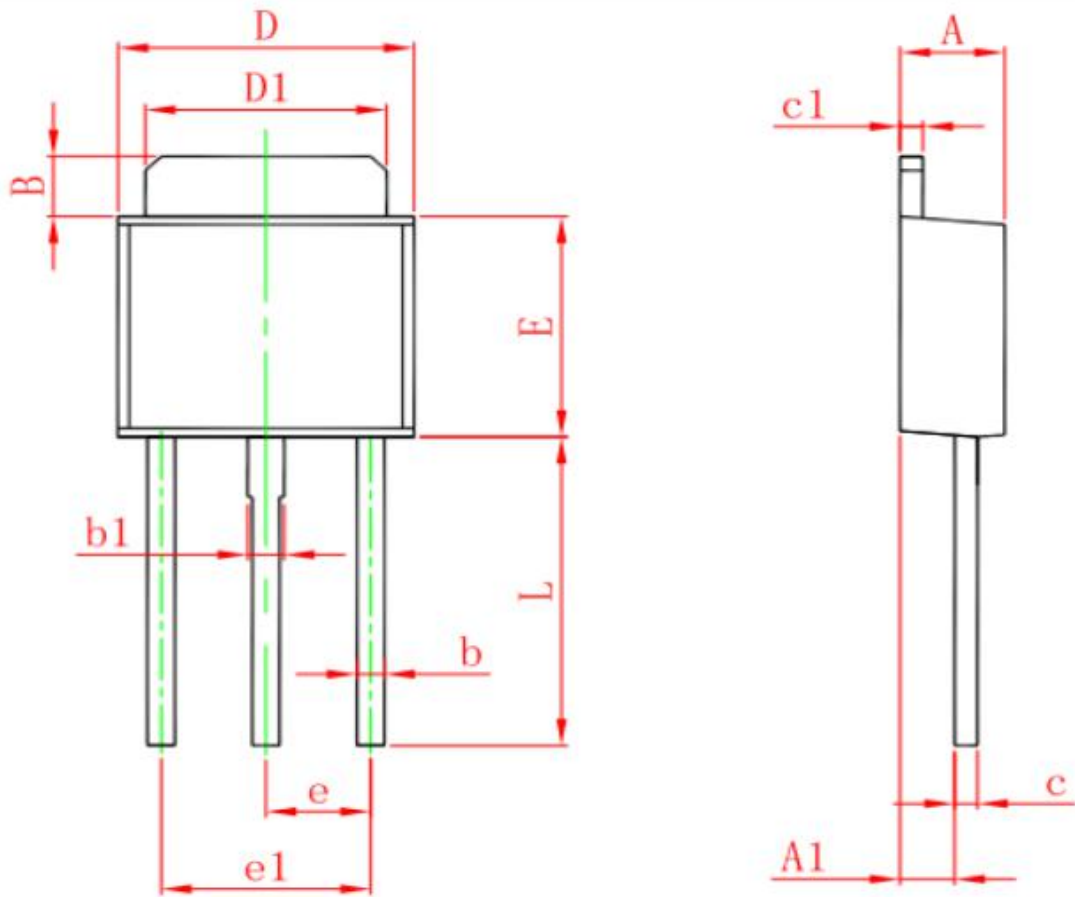

Symbol	Dimensions In Millimeters		Dimensions In Inches	
	Min.	Max.	Min.	Max.
A	2.200	2.400	0.087	0.094
A1	1.050	1.350	0.042	0.054
B	1.350	1.650	0.053	0.065
b	0.500	0.700	0.020	0.028
b1	0.700	0.900	0.028	0.035
c	0.430	0.580	0.017	0.023
c1	0.430	0.580	0.017	0.023
D	6.350	6.650	0.250	0.262
D1	5.200	5.400	0.205	0.213
E	5.400	5.700	0.213	0.224
e	2.300 TYP.		0.091 TYP.	
e1	4.500	4.700	0.177	0.185
L	7.500	7.900	0.295	0.311