

## Single Line Bi-directional Transient Voltage Suppressor

### DESCRIPTION

The SD4V5FDTC TVS diode is designed to replace multilayer varistors (MLVs) in portable applications such as cell phones, notebooks, and PDA's. It offers superior electrical characteristics such as low clamping voltage, low leakage current and high surge capability. It is designed to protect sensitive electronic components which are connected to power lines, from over-stress caused by ESD (Electrostatic Discharge), EFT (Electrical Fast Transients) and Lighting.

The SD4V5FDTC is in a DFN1610-2L package and will protect one bidirectional line. It may be used to provide ESD protection up to  $\pm 30\text{kV}$  (Contact and air discharge) according to IEC61000-4-2, and withstand peak pulse current up to 160A (8/20 $\mu\text{s}$ ) according to IEC61000-4-5.

### ORDERING INFORMATION

- ✧ Device: SD4V5FDTC
- ✧ Package: DFN1610-2L
- ✧ Marking: D4N
- ✧ Material: Halogen free and RoHS compliant
- ✧ Packing: Tape & Reel
- ✧ Quantity per reel: 3,000pcs

### PIN CONFIGURATION

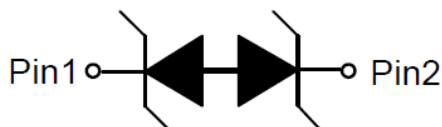

### FEATURES

- ✧ Transient protection for high-speed data lines  
IEC 61000-4-2 (ESD)  $\pm 30\text{kV}$  (Contact)  
 $\pm 30\text{kV}$  (Air)
- ✧ Peak power dissipation: 3200W (8/20 $\mu\text{s}$ )
- ✧ Working voltages : 4.5V
- ✧ Low leakage current
- ✧ Low clamping voltage
- ✧ Ultra-small package (1.6mm $\times$ 1.0mm $\times$ 0.5mm)
- ✧ Solid-state silicon-avalanche technology

### MACHANICAL DATA

- ✧ DFN1610-2L package
- ✧ Flammability Rating: UL 94V-0
- ✧ High temperature soldering guaranteed:  
260 $^{\circ}\text{C}$ /10s
- ✧ Packaging: Tape and Reel
- ✧ Reel size: 7 inch

### APPLICATIONS

- ✧ Power lines
- ✧ Personal digital assistants (PDA's)
- ✧ Microprocessors based equipment
- ✧ Notebooks, Desktops, and Servers
- ✧ Cell phone Handsets and Accessories
- ✧ Portable Electronics
- ✧ Peripherals

### PACKAGE OUTLINE

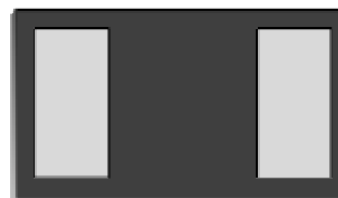

## Single Line Bi-directional Transient Voltage Suppressor

### ABSOLUTE MAXIMUM RATING

Symbol	Parameter	Value	Units
V <sub>ESD</sub>	ESD per IEC 61000-4-2 (Contact)	±30	kV
	ESD per IEC 61000-4-2 (Air)	±30	
P <sub>PP</sub>	Peak Pulse Power (8/20μs)	3200	W
T <sub>OPT</sub>	Operating Temperature	-55~125	°C
T <sub>STG</sub>	Storage Temperature	-55~150	°C
T <sub>L</sub>	Lead Soldering Temperature	260(10sec)	°C

### ELECTRICAL CHARACTERISTICS (T<sub>amb</sub>=25°C)

Symbol	Parameter	Test Condition	Min	Typ	Max	Units
V <sub>RWM</sub>	Reverse Working Voltage				4.5	V
V <sub>BR</sub>	Reverse Breakdown Voltage	I <sub>T</sub> = 1mA	4.6	5.2	6.4	V
I <sub>R</sub>	Reverse Leakage Current	V <sub>RWM</sub> = 4.5V			1	uA
I <sub>PP</sub>	Peak Pulse Current	t <sub>p</sub> = 8/20μs			160	A
V <sub>C</sub>	Clamping Voltage	I <sub>PP</sub> = 50A, t <sub>p</sub> = 8/20μs		8.5	11	V
		I <sub>PP</sub> = 100A, t <sub>p</sub> = 8/20μs		12	14	V
		I <sub>PP</sub> = 160A, t <sub>p</sub> = 8/20μs		17	20	V
C <sub>J</sub>	Junction Capacitance	V <sub>R</sub> = 0V, f = 1MHz		300	500	pF

## ELECTRICAL CHARACTERISTICS CURVE

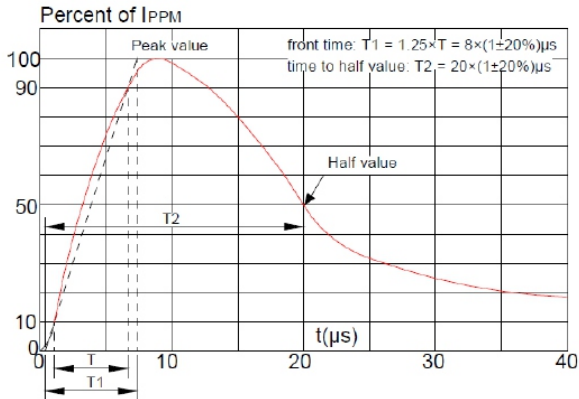

Pulse Waveform (8/20us)

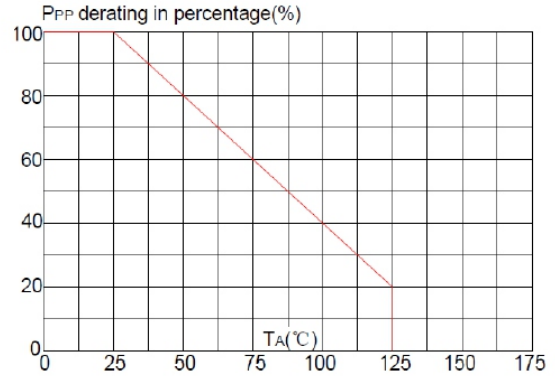

Pulse Derating Curve

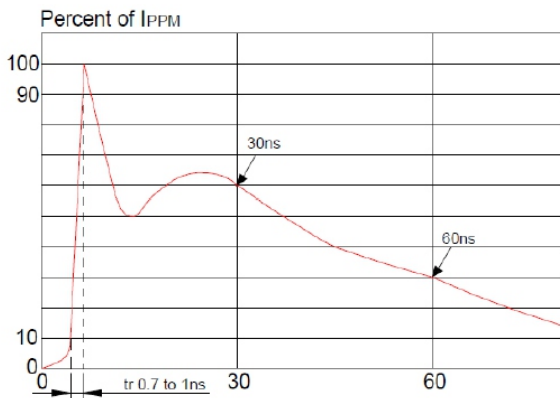

ESD Clamping(8kV Contact Discharge )

## DFN1610-2L PACKAGE OUTLINE DIMENSIONS

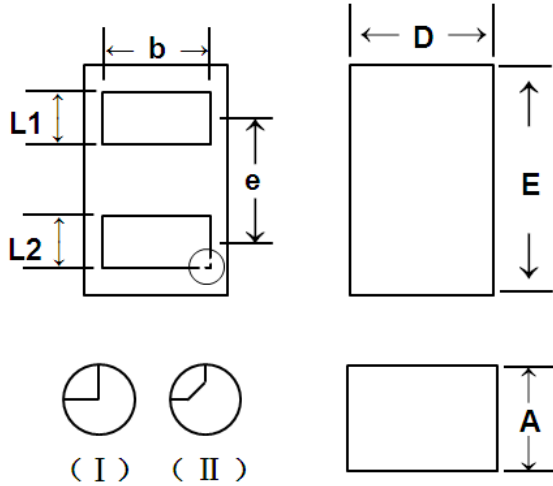

NOTE: ALL DIMENSIONS IN MM

	MIN	NOM	MAX
D	0.95	1.00	1.05
E	1.55	1.60	1.65
L1	0.35	0.40	0.45
L2	0.35	0.40	0.45
A	0.45	0.50	0.55
b	0.85	0.90	0.95
e	1.1BSC		

### Recommend Land Pattern (Unit: mm)

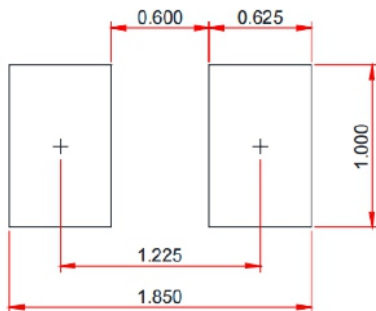

Note:

This recommended land pattern is for reference purpose only.