

### Surface Mount Ultrafast Recovery Rectifier

Reverse Voltage – 50V~1000 V

Forward Current – 3.0 A

### FEATURES

- For surface mounted applications
- Low profile package
- Glass Passivated Chip Junction
- Superfast reverse recovery time
- Lead free in comply with EU RoHS 2011/65/EU directives

### MECHANICAL DATA

- Case: SMBF
- Terminals: Solderable per MIL-STD-750, Method 2026
- Approx. Weight: 57mg / 0.002oz

### PINNING

PIN	DESCRIPTION
1	Cathode
2	Anode

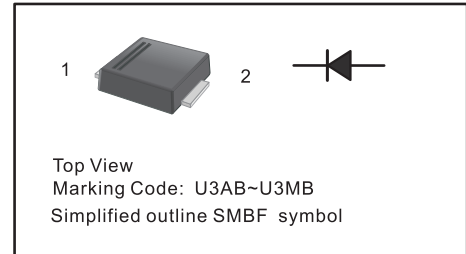

### Maximum Ratings and Electrical characteristics

Ratings at 25 °C ambient temperature unless otherwise specified.

Single phase half-wave 60 Hz, resistive or inductive load, for capacitive load current derate by 20 %.

Parameter	Symbols	US3ABF	US3BBF	US3DBF	US3GBF	US3JBF	US3KBF	US3MBF	Units	
Maximum Repetitive Peak Reverse Voltage	$V_{RRM}$	50	100	200	400	600	800	1000	V	
Maximum RMS voltage	$V_{RMS}$	35	70	140	280	420	560	700	V	
Maximum DC Blocking Voltage	$V_{DC}$	50	100	200	400	600	800	1000	V	
Maximum Average Forward Rectified Current at $T_a = 65\text{ }^\circ\text{C}$	$I_{F(AV)}$	3							A	
Peak Forward Surge Current 8.3 ms Single Half Sine Wave Superimposed on Rated Load (JEDEC Method)	$I_{FSM}$	100							A	
Maximum Instantaneous Forward Voltage at 3 A	$V_F$	1.0		1.3		1.6			V	
Maximum DC Reverse Current $T_a = 25\text{ }^\circ\text{C}$ at Rated DC Blocking Voltage $T_a = 125\text{ }^\circ\text{C}$	$I_R$	5 100							$\mu\text{A}$	
Typical Junction Capacitance <sup>1)</sup>	$C_j$	75							pF	
Maximum Reverse Recovery Time <sup>2)</sup>	$t_{rr}$	50				75				ns
Typical Thermal Resistance <sup>3)</sup>	$R_{\theta JA}$ $R_{\theta JL}$	55 16							$^\circ\text{C/W}$	
Operating and Storage Temperature Range	$T_j, T_{stg}$	-55 ~ +150							$^\circ\text{C}$	

1) Measured at 1 MHz and applied reverse voltage of 4 V D.C

2) Measured with  $I_F = 0.5\text{ A}$ ,  $I_R = 1\text{ A}$ ,  $I_{rr} = 0.25\text{ A}$

3) P.C.B. mounted with 0.5 X 0.5" (12.7 X 12.7 mm<sup>2</sup>) copper pad areas.

**Fig.1 Reverse Recovery Time Characteristic And Test Circuit Diagram**

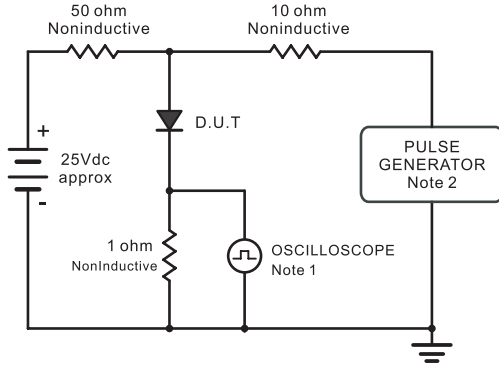

Note 1. Rise Time = 7ns, max.  
Input Impedance = 1megohm, 22pF.  
Note 2. Rise Time = 10ns, max.  
Source Impedance = 50 ohms.

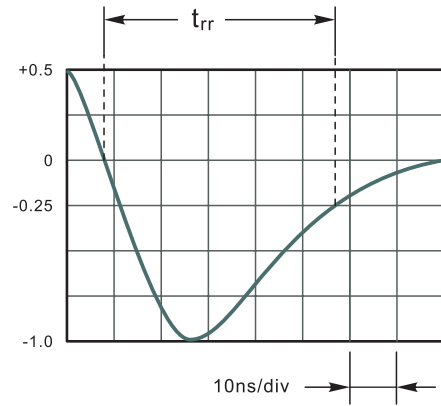

Set time Base for 10ns/div

**Fig.2 Maximum Average Forward Current Rating**

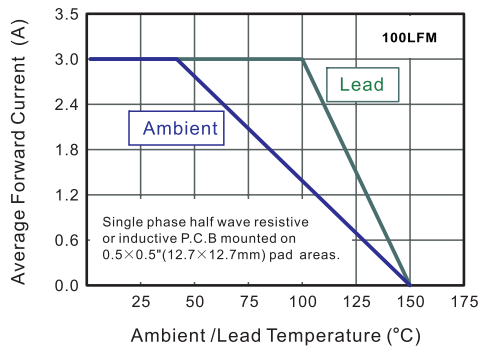

**Fig.3 Typical Reverse Characteristics**

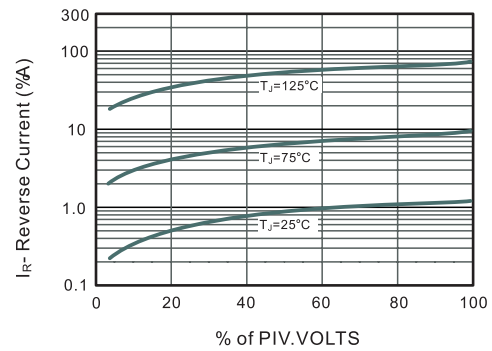

**Fig.3 Typical Instantaneous Forward Characteristics**

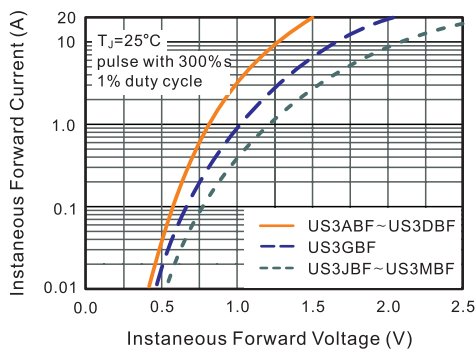

**Fig.4 Maximum Non-Repetitive Peak Forward Surge Current**

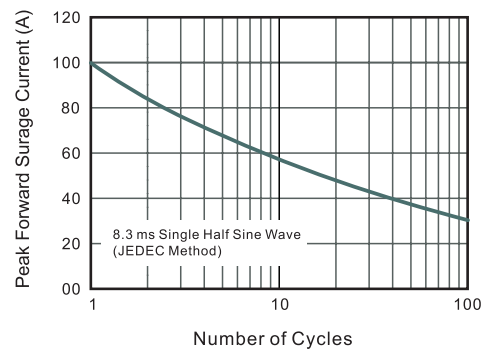

### PACKAGE OUTLINE

Plastic surface mounted package; 2 leads

SMBF

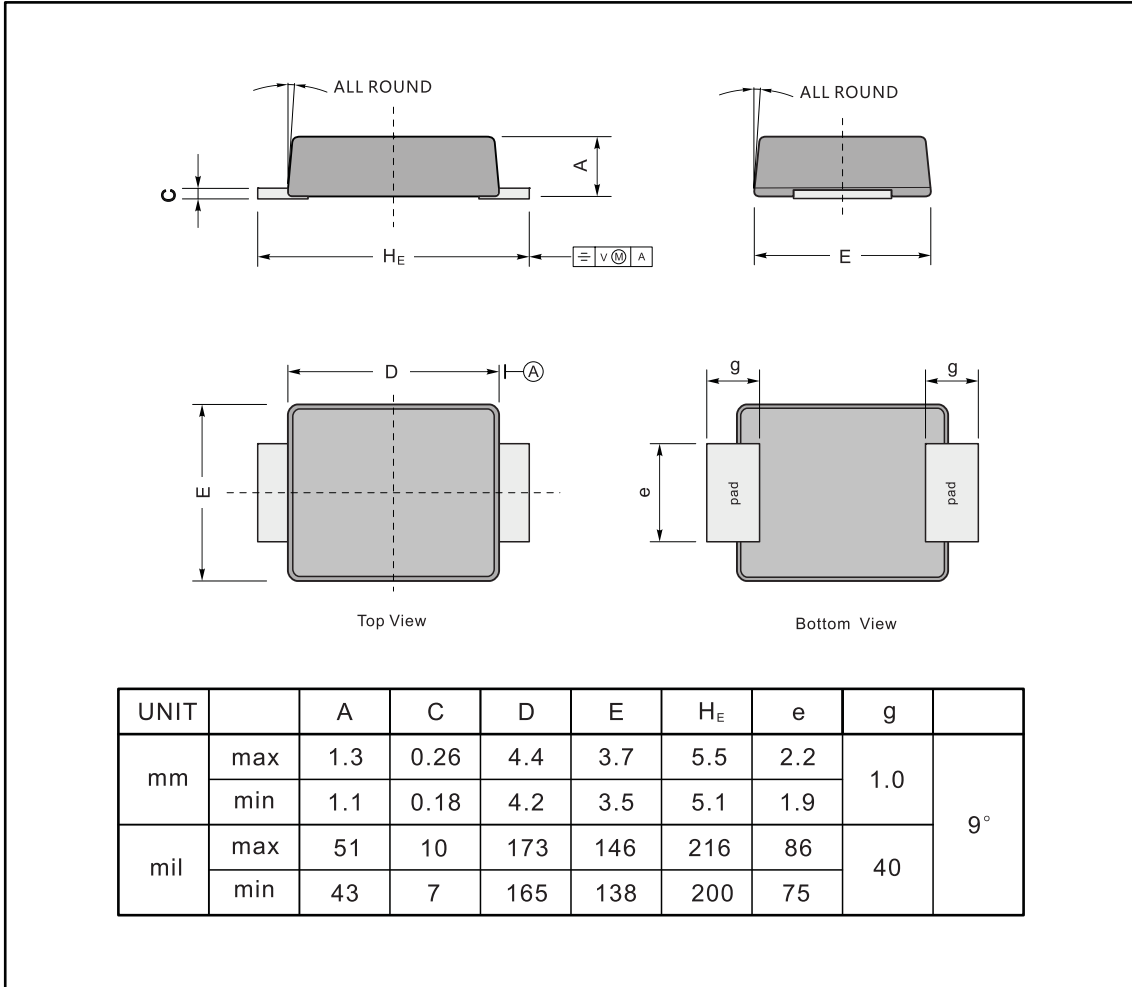

### The recommended mounting pad size

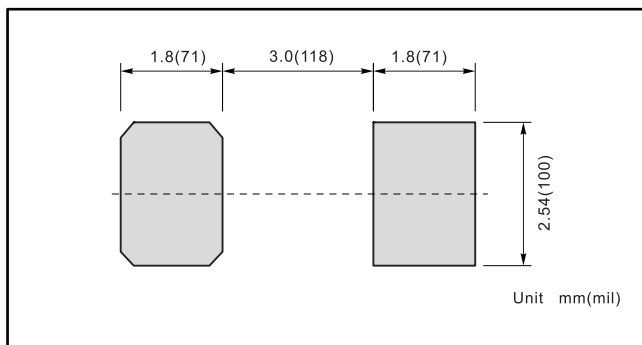

### Marking

Type number	Marking code
US3ABF	U3AB
US3BBF	U3BB
US3DBF	U3DB
US3GBF	U3GB
US3JBF	U3JB
US3KBF	U3KB
US3MBF	U3MB